

# METHODS OF MEASURING SOIL CREEP

M J. Selby\*

---

## SUMMARY

Methods of measuring soil creep which are already in use are classified and discussed. Methods which will be used in a comparative study of mass movement on volcanic ashes and pumice are described.

## INTRODUCTION

Creep is defined by Sharpe (1938, p.21) as the 'slow down-slope movement of superficial soil or rock debris, usually imperceptible except to observations of long duration'. Parizek and Woodruff (1957) suggest that the term has become ambiguous and all-inclusive to include slow down-slope processes which are not readily recognizable but which are deduced as being present. They object particularly to the ambiguity of the rate of the process, and the meaning of the word 'superficial'. They ignore the paper by Terzaghi (1950) in which Sharpe's definition is accepted and refined. Terzaghi indicates that there are two types of creep — seasonal and continuous. Seasonal creep occurs within 'the zone of seasonal changes of moisture and temperature' (p.84). These changes produce swelling and shrinking, freezing and thawing, and other horizontal components of ground movement. They result in down-hill movement of a sheet of soil and regolith material with a 'depth equal to or smaller than the depth of seasonal variations in the condition of the ground'. Most measurements of creep so far have recorded seasonal creep. Continuous creep occurs beneath the depth of seasonal variations and is entirely the result of gravitational forces, which are constant. The definition of Sharpe, as amplified by Terzaghi, will be adopted here. Blong (1966) has reviewed other definitions and discussed the possible mechanisms of creep.

## METHODS OF MEASUREMENT

Methods used in the measurement of soil creep can be divided into four groups: those involving the movement of surface stakes, pins and markers, or columns in the ground; those which involve measurement of tilt bars or deformation of tubes; those which measure movement of plates in the ground; and laboratory studies.

---

\* University of Waikato.

## Movement of Stakes, Pins and Markers, or Tubes and Columns in the Ground.

The simplest measurements of soil creep are those which are obtained from the movement of stakes and pins in the ground. Miller and Leopold (1963, p.425) describe the use of metal stakes 7 - 12 in. long set in lines at 5 to 10-foot spacings along contours. They are driven in vertically and allowed to protrude  $\frac{1}{2}$  - 1 in. The two ends of the line are monumented so that a transit can be set up over the monument and the successive positions of the stakes can be recorded. Sections of reinforcing rods, nails and metal tubes have been used as stakes. Leopold, Wolman and Miller (1964, p.352) describes such a survey over a 4-year period. The tops of the stakes, at the end of the period, were actually up slope of the original position — probably indicating that rotation, caused by greater subsurface than surface movement in the soil, was occurring.

Young (1960) used a similar method but placed metal pegs in the ground down slope from a bench mark engraved on a rock near the head of the slope (Fig. 1A). Schumm (1956) and Rapp (1962) have also used stakes, and a number of workers have placed articles varying from wooden blocks to painted stones on the surface of the soil and surveyed their position at intervals of time — Washburn (1947, 1960), Michaud (1950), Schmid (1955), Jahn (1960), Smith (1960) and Klinger (1959). This last group of people and Rapp were all working in periglacial environments.

In New Zealand, O'Loughlin (1966) intends to measure the movement of 4-foot steel standards set in the surface of narrow screes. The standards will be located beneath a strand of No. 9 wire from which a plumb-bob can be suspended. The position of each stake can be measured at intervals by reference to the wire and plumb-bob.

The methods so far described allow continuous study of movements but give little indication of what is happening beneath the ground surface. Hadley (unpublished) and Schumm (1964) have bored auger holes and filled them with glass beads, and Hadley (unpublished) and Iveronova (1964) have used wood dowels; plugs of modelling clay previously frozen in dry ice have also been proposed. The holes are generally less than 20mm. in diameter and 1 - 1.5m. in depth. Cassidy (reported in Kirkby, 1965), and Rudberg (1958, 1962) have used plastic tube or sections of tubing in a similar way. The great difficulty with all of these methods is that re-location and excavation are extremely difficult and liable to disturb the inserted materials. Cassidy partly overcame this by filling his tubes with quick-setting cement before excavating them.

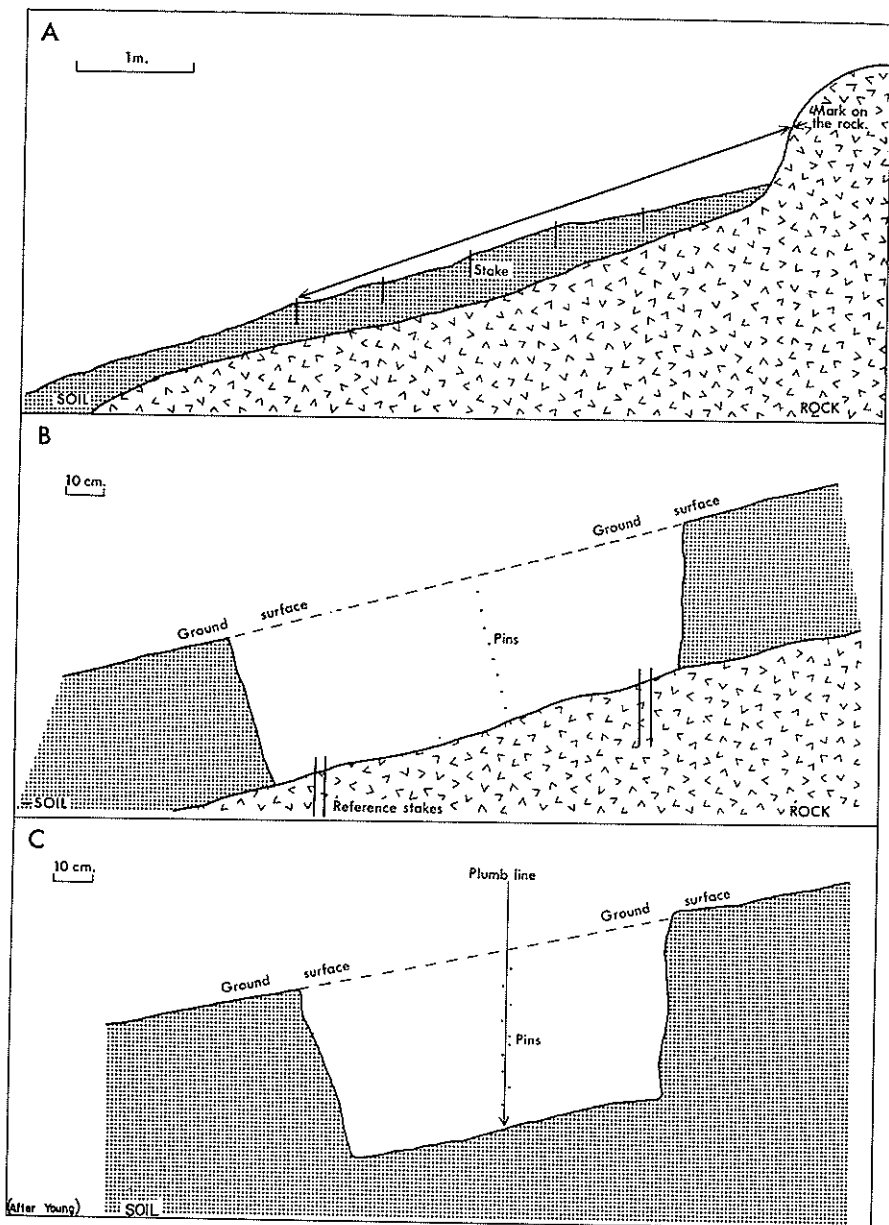

FIGURE 1

Young (1960, 1963) has dug a pit (Figs. 1 B and 1C) and pushed fine wires 2 - 4 in. long into the sides. The pins are located with reference to a plumb-line with calipers, or with reference to stakes driven into the bedrock. The bottom wires were about 15 in. deep and assumed to be below the depth at which movement takes place. The sides of the pit which contained the wires were covered with brown paper and the holes filled in. The pits were re-excavated after six months but the disturbance of the soil, the problem of re-location, the possibility of increased water percolation down the sides of the pit, the infrequency of possible readings and the experimental errors make the value of this method uncertain.

### Measurements using Tilt Bars and Deformation of Tubes.

In order to make frequent measurements of creep it is necessary to have instruments which do not require to be located by survey and which record very small movements. Kirkby (1965) used a tilt bar (Fig. 2A) which is a steel rod 9 or 15 in. long of  $\frac{1}{4}$  in. square-section mild steel. It has a crosspiece of steel with a brass strip attached and parallel to it, on which is mounted a sensitive spirit level. At one end of the brass strip is an adjusting screw which can be used to set the bubble after each measurement. Each graduation on the level shows a tilt of 10 sec. of arc and tilts of  $\pm 50$  sec. of arc can be observed directly. The tilt bars were inserted in the soil to depths of 6 and 12 in. and placed in pairs. Measurements were made at three-day intervals. This instrument is very easily disturbed by animals or people and therefore has to be fenced. Its design involves the assumption that the rate of shear is averaged over the length of the tilt bar.

Measurement of deformation of tubes set vertically in the ground has been made by several workers. Cassidy (reported by Kirkby, 1965) measured the deformation of his tubes by lowering an inclinometer into them, but he found that this was not a sensitive method and that he had to use a wide tube of  $1\frac{1}{4}$  in. diameter. Dury (1959, p.15) describes a method which he says has been used in the U.S.A., for which he does not give a reference. It involves measuring the inclination of a metal tube by removing the cap on the tube at intervals and lowering into it a glass container of hydrofluoric acid (Fig. 2B). The container is allowed to remain stationary at a given depth while the acid etches a horizontal ellipse inside it. The angle between the plane of the ellipse and the side of the container gives the angle of slope of the metal tube at a particular depth. A series of measurements gives the profile of each tube and the rate of creep at varying depths.

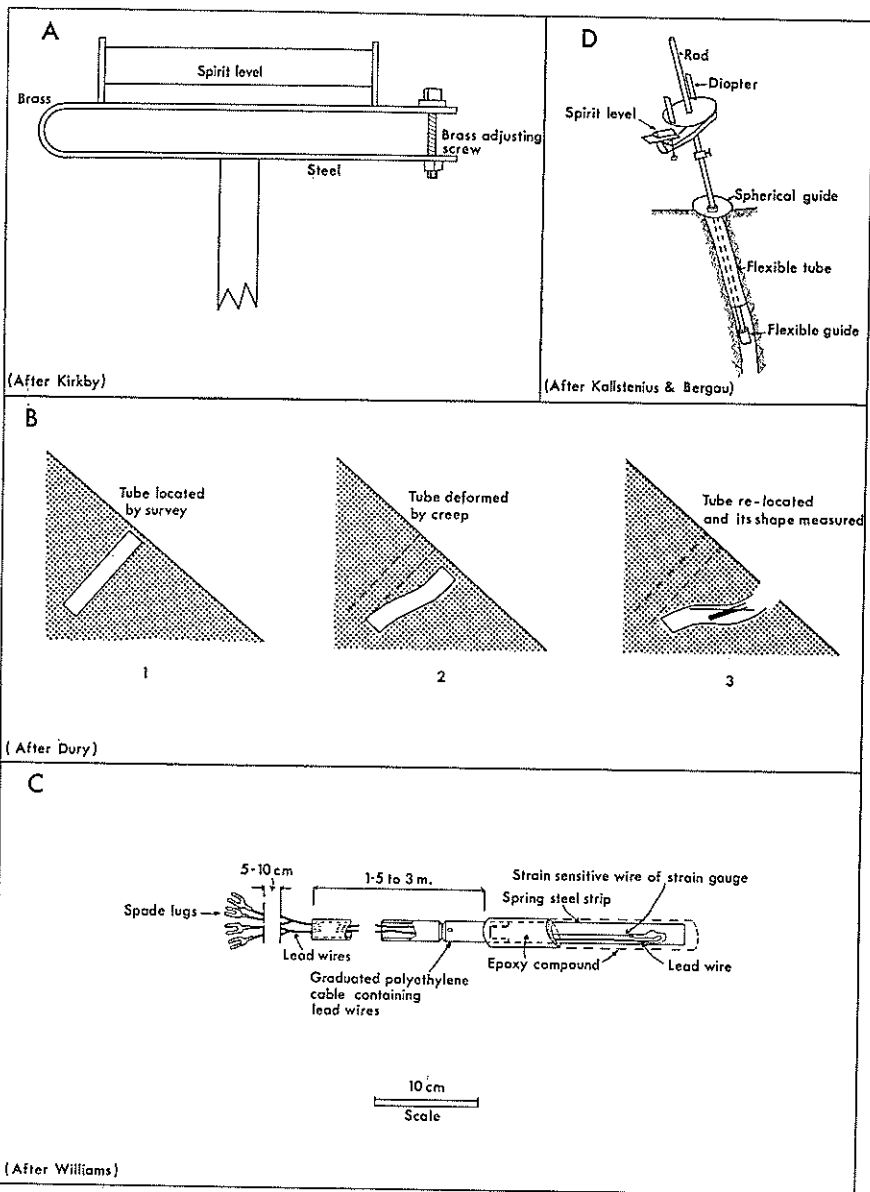

FIGURE 2

Williams (1957, 1959, 1962a, 1962b), working in periglacial environments, has used plastic tubes, of 1.5-cm. internal diameter and 0.15-cm. wall thickness, which are buried in the ground with the top of the tube exposed.

The curvature of the tube resulting from soil movements was determined at intervals by the insertion of a specially-constructed probe. The bottom of the plastic tube should be at a depth greater than that of soil movement, and the top located by survey.

The probe is a cylinder of epoxy resin with a diameter only slightly less than that of the internal diameter of the plastic tube. The probe contains a spring steel strip of about 0.1-cm. thickness, in which are mounted electrical-resistance strain gauges (Fig. 2C). The probe, when inserted into the tube, assumes the curvature of the tube and the strain set up in the spring steel is proportionate to that in the strain gauges. Leads from the probe pass along a semi-rigid tube attached to the probe to a resistance-measuring bridge on the ground surface. With the aid of a calibration table the resistance readings may be converted into a measure of curvature. The probes in use so far have been used to record movements of up to 25cm. during spring solifluxion movements.

Kallstenius and Bergau (1961) reported that the workers at the Swedish Geotechnical Institute have devised an inclinometer which has some of the properties of Kirkby's and William's instruments. This rod inclinometer may be placed inside a flexible tube which is inserted vertically into the ground to a maximum depth of 4m. The inclinometer consists of a straight rod with a flexible guide which follows the bends of the tube (Fig. 2D). Where the rod enters the tube it is centred by means of a disc and a spherical guide. The inclination and length of the rod between the guides determines the position of the centre of the lower guide in relation to the centre of the spherical guide. The direction and angle of the inclination are measured by means of an instrument mounted on the rod. The instrument consists of a diometer and a spirit level which can be adjusted to give an indication of the position and inclination of the rod. To take a measurement the rod is inserted to the required depth and the readings taken.

The Swedish Geotechnical Institute has developed two other instruments for use at depths of up to 90m. and for giving warning of dangerous earth movements; these also are described in the paper by Kallstenius and Bergau.

## Buried Plates

Everett (1962, 1963) has used small aluminium pressure plates anchored vertically in the soil and connected to the shaft of a potentiometer by an aluminium rod. Movements of the soil against the plate caused displacements of the potentiometer shaft and a resistance change which was measured by a modified Wheatstone bridge. These instruments have been used in Ohio and Alaska where they have recorded movements caused by freezing and thawing, and wetting and drying of soils.

## Laboratory Measurements

Davison (1889) may have been the first worker to measure soil movements in laboratory conditions. He set a tray of soil at an angle with a pointer mounted on the soil. He noted the position of the pointer before and after a night frost, and determined that the surface of the soil had risen vertically during the freezing and fallen at an angle in a down-slope direction during the thawing. Other laboratory experiments have been conducted by Young (1958) and Kirkby (1965). They used soil blocks in inclined troughs with glass sides. Metal pins were pushed into the sides of the blocks and their position measured at intervals of about 40 days, during which the soil was wetted and dried. The pins were generally found to move both down-slope and vertically downwards.

## CONCLUSIONS AND PROPOSALS

It is suggested that the ideal instruments for measuring soil creep should be cheap, sturdy, able to be read at any time and not easily disturbed by people or animals. The instruments should also unambiguously measure soil creep, and not any other processes, and should not themselves cause soil movements or disturbances. As part of a study of soil erosion on the pumice country of the central North Island, it is proposed to use a number of methods of recording soil creep. The main instrument will be a tilt bar of 0.5 x 2.5 cm. mild steel (Fig. 3A). The bars have an L shape and can be inserted into the ground to depths of 15, 30 and 40 cm. They will be set vertically into the ground in lines parallel to the contours and their position surveyed in relation to bench marks of angle iron driven deeply into the ground. The angle of tilt can be measured with a sensitive abney level or a clinometer. Alongside the tilt bars resistance blocks will be buried at known depths so that soil moisture can be recorded at the same time. Soil distance thermographs with three probes will continuously record soil temperatures at known depths. In the same area plastic tubes of the same specifications as those used by Williams (1957)

will be inserted into auger holes normal to the soil surface. The holes will be made using an auger guide (Fig. 3B). Williams's calculations suggest that this tubing has no effect on the mechanics of the soil, whereas wood dowelling, blocks of clay and heavy tubes or metal bars possibly do have such an effect. Young pits and auger holes filled with glass beads will also be used. The combination of these methods should indicate when movements occur (tilt bars) and the velocity profiles of shearing and non-shearing movements (beads and tubes). The beads, tubes and Young pits can be examined only at long intervals but the tilt bars and moisture and temperature readings should indicate the periods of maximum movement and their causes. A series of laboratory experiments should give a better understanding of the processes and extent of creep in different soils. It is hoped that the problems of interference with instruments can be avoided by siting the experiments in experimental basins.

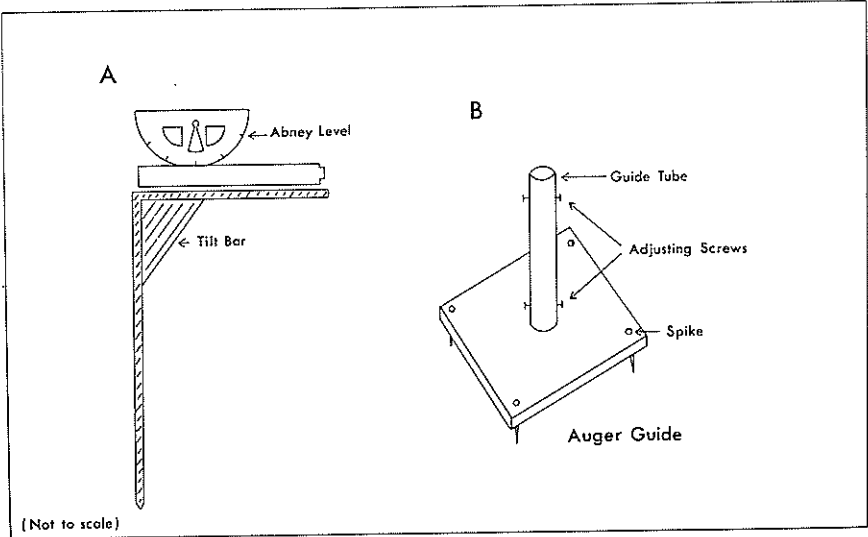

FIGURE 3

## REFERENCES

- Blong, R. J. 1966: Soil creep: a review. *Auckland Student Geographer*, Vol. 3 (in press).
- Davison, C. 1889: On the creeping of the soil cap through the action of frost. *Geol. Mag.*, Vol. 6, pp.255-61.
- Dury, G. H. 1959: *The face of the earth*, Pelican, 223p.
- Everett, K. R. 1962: Quantitative measurement of soil movement. *Geol. Soc. Amer. Special Paper* 73, pp. 147-8.
- Everett, K. R. 1963: Slope movement, Neotoma Valley, Southern Ohio. *Inst. of Polar Studies* (Ohio State Univ.) Report 6, 59p.
- Hadley, R. F. (unpub.): Selecting sites for observation of geomorphic and hydrologic processes through time. *U.S. Geol. Surv.*, Denver, Colorado.
- Iveronova, M. I. 1964: Stationary studies of the recent denudation processes on the slopes of the river Tchou-Kizilsu Basin. Tersky Alatau Ridge, Tien Shan. *Zeit. fur Geomorphologie Supplementband* 5, pp.206-12.
- Jahn, A. 1960: Some remarks on evolution of slopes on Spitsbergen. *Zeit. fur Geomorphologie Supplementband* 1, pp.49-58.
- Kallstenius, T.; Bergau, W. 1961: In situ determination of horizontal ground movements. *Proc. 5th Int. Conf. Soil Mechanics & Foundation Engineering*, Vol. 1, pp.481-5.
- Kirkby, M. J. 1965: A study of rates of erosion and mass movements on slopes, with special reference to Galloway. *Unpublished Ph.D. Dissertation*, University of Cambridge, 436p.
- Klinger, R. 1959: Beobachtungen uber die Denudation im Spitzinseegebiet. *Mitt. Geogr. Ges. Munchen*, 44.
- Leopold, L. B.; Wolman, M. G.; Miller, J. P. 1964: *Fluvial processes in geomorphology*, W. H. Freeman & Co., 522p.
- Michaud, J. 1950: Emploi de marques dans l'etude des mouvements du sol. *Revue Geomorph. Dyn.*, Vol. 1.
- Miller, J. P.; Leopold, L. B. 1963: Simple measurements of morphological changes in river channels and hill slopes, In 'Changes of climate', *Arid Zone Research Series*, UNESCO, pp.421-7.
- O'Loughlin, C. 1966: Determination of scree sediment mobility: preliminary experiments. *Unpublished. Forest & Range Expt. Sta., Rangiora*, 2p.
- Parizek, E. J.; Woodruff, J. F. 1957: A clarification of the definition and classification of soil creep. *J. Geol.*, Vol. 65(6), pp.653-6.
- Rapp, A. 1962: Karkevagge. Some recordings of mass movements in the Northern Scandinavian mountains. *Biuletyn Peryglacialny*, No. 11, pp.287-309.
- Rudberg, S. 1958: Some observations concerning mass movements on slopes in Sweden. *Geol. Foren, Stockholm Forhandl.*, Bd. 81.
- Rudberg, S. 1964: Slow mass movement processes and slope development in the Norra Storffjall area, Southern Swedish Lappland. *Zeit. fur Geomorphologie Supplementband* 5, pp.192-203.
- Schmid, J. 1955: *Der Bodenfrost als Morphologischer Faktor*, Heidelberg.
- Schumm, S. A. 1956: The role of creep and rainwash on the retreat of Badland slopes. *Amer. J. Science*, Vol. 254, pp.693-706.

- Schumm, S. A. 1964: Seasonal variations of erosion rates and processes on hillslopes in Western Colorado. *Zeit. fur Geomorphologie Supplementband* 5, pp.215-38.
- Sharpe, C. F. S. 1960: *Landslides and Related Phenomena*, Pageant Books, 125p.
- Smith, J. 1960: Cryoturbation data from South Georgia. *Biuletyn Peryglacjalny*, No. 8.
- Terzaghi, K. 1950: Mechanism of landslides *Geol. Soc. Amer. Engineering Geology (BerkeyVol.)* pp.83-123. .
- Washburn, A. L. 1947 Reconnaissance geology of portions of Victoria Island and adjacent regions, Arctic Canada. *Geol. Soc. Amer. Mem.* 22.
- Washburn, A. L. 1960: Instrumentation for mass-wasting and patterned-ground studies inn Northeast Greenland. *Biuletyn Peryglacjalny*, No. 8.
- Williams, P. J. 1957: The direct recording of solifluction movements. *Amer. J. Science*, Vol. 255, pp.705-15.
- Williams, P. J. 1959: An investigation into processes occurring in solifluction. *Amer. J. Science*, Vol. 257, pp.481-90.
- Williams, P. J. 1962a: An apparatus for investigation of the distribution of movement with depth in shallow soil layers. *Building Note 39 (N.R.C. Canada)*, 10p.
- Williams, P. J. 1962b: Quantitative investigations of soil movement in frozen ground phenomena. *Biuletyn Peryglacjalny*, No. 11, pp. 353-62.
- Young, A. 1958: Some considerations of slope form and development, regolith and denudation processes. *Unpublished Ph.D. Dissertation, University of Sheffield.*
- Young, A. 1960: Soil movement by denudation processes on slopes. *Nature*, Vol. 188(4746), pp. 120-2.
- Young, A. 1863: Soil movement on slopes. *Nature*, Vol. 200(4902). pp. 129-30.